



Roofers Edge Fascia

Installation Guide for Roofers Edge Fascia

4 COMMERCE WAY, ARDEN, NC 28704 USA
800-892-9173 828-676-1700
OMGEDGESYSTEMS.COM



EdgeSystems



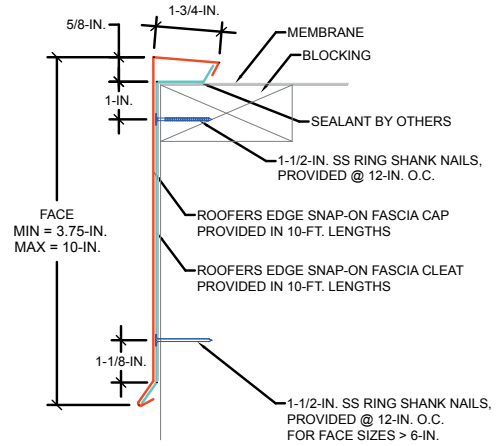

Installation Guide for Roofer's Edge Fascia

FOR MASONRY APPLICATIONS, PLEASE CONTACT OMG.

CONTACT OMG FOR APPROPRIATE RECOMMENDATIONS NEEDED TO MEET/EXCEED
ANSI/SPRI/FM4435/ES-1 DESIGN CRITERIA

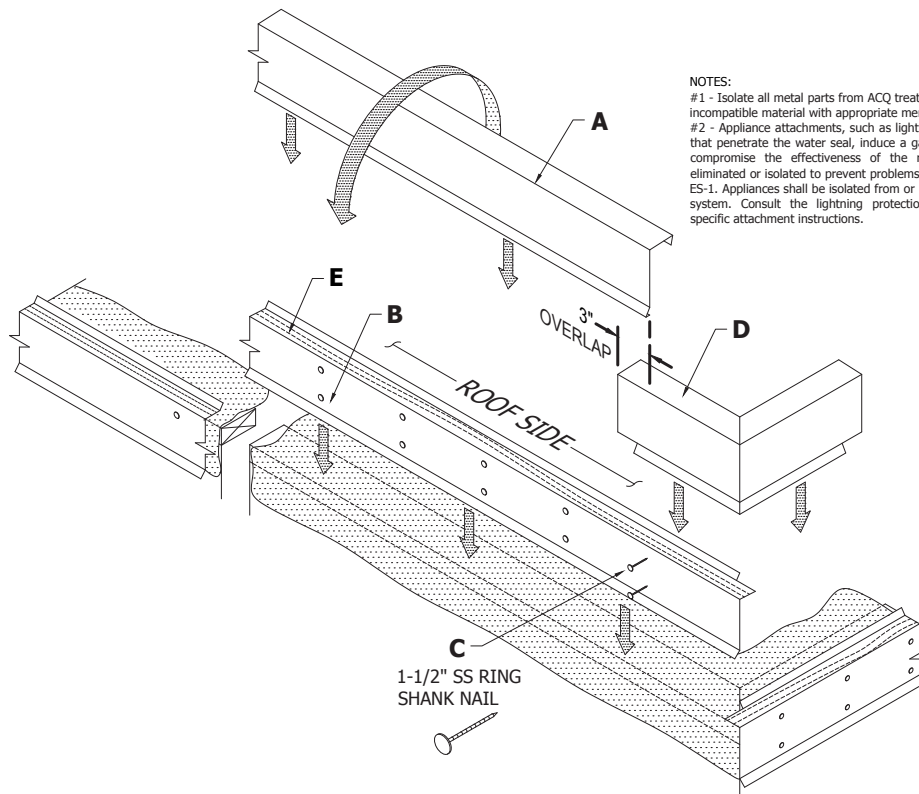

NOTES:

- #1 - Isolate all metal parts from ACQ treated wood or other galvanically incompatible material with appropriate membrane material.
- #2 - Appliance attachments, such as lightning rods, signs, or antennae that penetrate the water seal, induce a galvanic reaction, or otherwise compromise the effectiveness of the roof edge system, shall be eliminated or isolated to prevent problems per section 8.0 of ANSI/SPRI ES-1. Appliances shall be isolated from or not attached to the roof edge system. Consult the lightning protection system manufacturer for specific attachment instructions.

A. Formed Fascia Cover
10'-0" Lengths

B. Galvanized Steel Cleat
10'-0" Lengths

C. 1-1/2" SS Ring Shank Nail
6" from ends @ 12" O.C.;
1" down from edge
1-1/8" above bottom bend (face sizes > 6")

D. Fascia Miter Cover
Field cut and folded
(Outside Corner Shown)

E. Water-Cut Off Mastic
(By Installer)

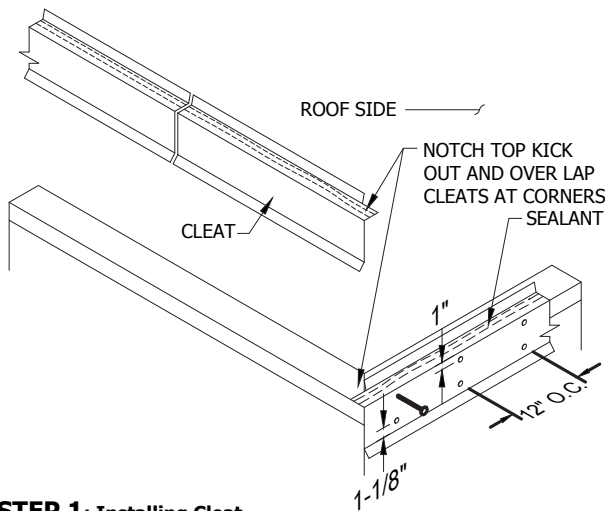

STEP 1: Installing Cleat

Apply a continuous bead of water-cut off mastic by others to the bottom side of the cleat. Install cleat working away from the corners. Attach the cleat using 1-1/2" SS ring shank nails at the locations shown above at 12" O.C. The lower row of fasteners are only required for face sizes > 6".

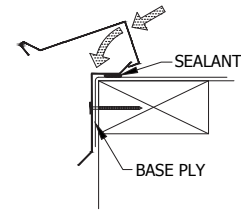

HOOK TOP ONTO CLEAT, ROTATE OVER, THEN PRESS DOWNWARD ON TOP FACE TO SNAP INTO POSITION
FASCIA INSTALL

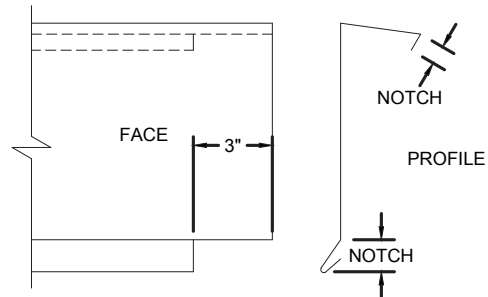

TYPICAL NOTCH PROCEDURE

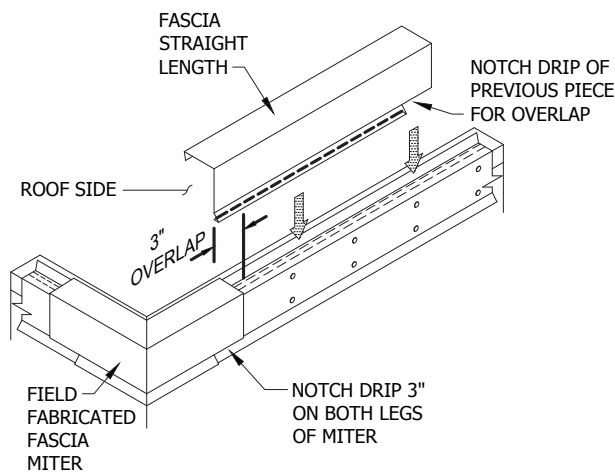

STEP 2: Installing Fascia Straight Lengths

Notch each drip of field fabricated miter 3". Then notch the drip of following 10'-0" piece as shown above. Install the fascia (see fascia install step). Review lengths of all straight pieces prior to cutting to avoid creating relatively short sections of fascia adjacent to full length sections.



4 COMMERCE WAY, ARDEN, NC 28704 USA
800-892-9173 828-676-1700 OMGEDGESYSTEMS.COM

Copyright © 2020 OMG, Inc. All rights reserved.

Superior productivity.
Superior performance.

